



Delta TRE 300



Delta TRE 300 with hopper under destemmer

The Delta TRE 300 mobile belt elevator enables:

- To feed destemmers, sorting tables, presses, maceration tanks... **with fresh grapes.**
- To feed presses with **macerated grapes.**
- To evacuate **stems and dried pomace.**



Hopper under destemmer (accessory)



Hopper at the end of sorting table (accessory)



Loosened belt



Directional gully on swivel (option)

Robustness

- Exposed stainless steel framework of 304L – folded sheet thickness 20/10 – sand-blasted.
- Belt with curved brackets width: 300 mm. Height: 60 mm.
- Double-folded stiff belt – in compliance with the FDA Food Approval – with stainless steel staples.
- On/Off button with a heat-proof system of the engine + 10 m. of wire.
- Hopper to be used either under Delta E2 destemmer, under tank door or at the end of sorting table.

Adaptability

- Inclination of elevator is adjustable from 30° to 50° max. by means of hydraulic cylinders and manual pump.
- Stainless steel trolley with 4 DN 125 wheels with brakes – polyurethane shrouding.

Juice collection

- Juice collector all along the framework.
- Juice evacuation thanks to 1 DN 50 “Macon” with bakelite plug.

Easy cleaning

- Exposed stainless steel framework giving way to below belt.
- Cleaning rubber of below belt.
- Quick release system of the belt.

Technical characteristics

- Drum motor on the top.

	A	B	C	D	E	F	G	H
3 m	310	180	10	640	1350	1960	2250	2900
4 m	310	180	610	1200	1820	2430	2990	3760
5 m	310	180	240	1300	2440	3060	3640	4410

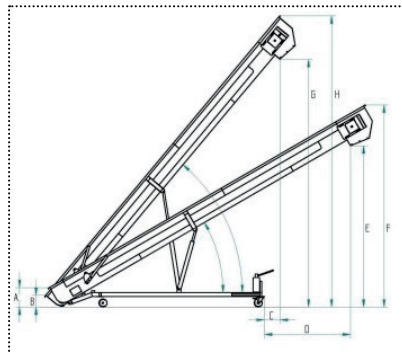

Options

- Motor equipped with a frequency variator.
- Flexible hose outlet length 700 mm.
- Directional gully with swivel length 1000 or 1500 mm.

Bucher Vaslin North America

3100 Dutton Avenue, Suite 134D
 Santa Rosa, CA 95407
 (707) 823-2883
 bvnorthamerica.com